

**Cape Royale Boating Association**  
**SAILING INSTRUCTIONS**  
**2009**

1. ELIGIBILITY – All CRBA members in good standing and their families are eligible to participate in CRBA events. Invited guests (non-CRBA members) are allowed to sail in CRBA. However, non-members will be scored only in open regattas.
2. QUALIFIERS – Any eligible CRBA member having paid required dues on or before the date of a particular event, who starts half or more of the races in that event, shall qualify for recognition in that event.
3. FLEETS – Handicap racing in CRBA shall be scored according to Portsmouth ratings when starts and finishes are recorded by the Race Committee. Otherwise, Portsmouth converted to time-on-distance ratings, or PHRF ratings shall be used with pursuit starts. Handicap values shall be the latest available to the Rear Commodore – Sailing at the beginning of a series.
4. SCHEDULE – The CRBA Events Calendar includes all planned sailing events. This plan shall be published and distributed to the general membership via the CRBA FOGHORN and/or electronic mail, and shall be posted on the CRBA website at [www.crba-livingston.com](http://www.crba-livingston.com). It shall be a part of these Sailing Instructions. The Events Calendar shall include the date and time of each event as well as the location and time of Skippers Meetings.
5. SCORING – Low-point scoring (1 point for 1st, 2 points for 2nd, etc.) shall be used. There shall be no scoring throw-outs.
  - DNF (did not finish) scores one more than the number of finishers in that race.
  - DSQ (disqualified) scores one more than the number of finishers in that race.
  - DNC (did not come) scores one more than the number of starters in the race (that day, or that Series, if applies) with the most starters.

TIES shall be broken as follows with the winner being the boat

- a) which has beaten the other tied boat(s) most often,
- b) with the most 1<sup>st</sup> place finishes,
- c) with the most 2<sup>nd</sup> place finishes, and so on,

When the tie still remains, the winner shall be the boat that finished highest in the last race in which all tied boats started. If tie still remains, the boats tied shall be awarded equal recognition.

Racing shall be governed by the most recent International Yacht Racing Rules, the prescriptions of U.S. Sailing, the pertinent class rules (except as any of these are altered by these sailing instructions), and by these sailing instructions.

ONE DESIGN CLASSES – At the discretion of the Rear Commodore – Sailing, and in coordination with the One Design Fleet’s captain, One Design classes may be scored separately.

6. AWARDS for each Series shall be granted as set forth below. Sailors must participate in at least 50% of all races to qualify for awards

3 to 4 Qualifiers	1 <sup>st</sup> Place
5 to 6 Qualifiers	1 <sup>st</sup> and 2 <sup>nd</sup> Place
7 or more Qualifiers	1 <sup>st</sup> , 2 <sup>nd</sup> , and 3 <sup>rd</sup> Place

SAILOR OF THE YEAR – The CRBA Sailor of the Year shall be the Member who shall earn the highest number of “SOY” points in a calendar year. SOY points shall be computed for each boat in each race as follows: Total number of starters + 1 – Finish Position. (Examples: 3<sup>rd</sup> place in race in which 5 boats started yields (5+1)-3, or 3 SOY points. 1<sup>st</sup> place in race in which 5 boats started yields (5+1)-1, or 5 SOY points.)

7. NOTICES TO PARTICIPANTS - Notices to participants shall be made by electronic mail and/or at Skippers’ Meetings.
8. ENTRIES - Eligible sailboats may participate by responding to the Sailing Commodore’s electronic mail or contacting him the day before the event. There shall not be any entry fees.
9. CHANGES IN SAILING INSTRUCTIONS - The Rear Commodore - Sailing shall via electronic mail or at the Skippers’ Meeting communicate any changes in these sailing instructions before the affected event begins.
10. SCHEDULE OF RACES - The CRBA Events Calendar has the planned starting times that are posted on the CRBA website. Except for the Long Distance Races, several races are planned for each racing date.
11. COURSES - The Rear Commodore – Sailing at the Skippers’ Meeting before each event shall provide the courses to be used for each event. There will not typically be a Committee Boat for the Long Distance Races or the Spring and Fall Series Events. The pursuit handicap system shall be used for these races and the Olympic Circle buoys shall be used to

set courses for the Spring & Fall Series Events. Course marks for Long Distance Races may include additional marks, as determined by the RCS. A race course can be designated by mentioning the Course Number (as shown below) along with the Letter Designation (as labeled on the Olympic Circle) of the first mark of the course.

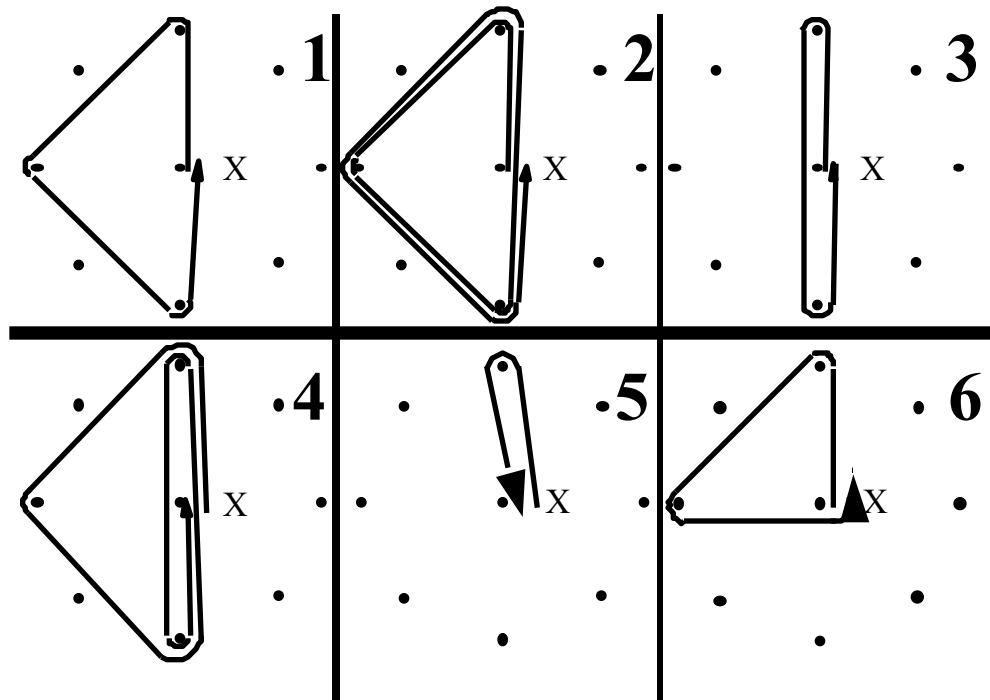

12. MARKS - The marks shall be orange buoys and/or white PVC buoys.
13. THE START – When using the Pursuit Handicap Starting Sequence or any other “time-on-distance” system, the Rear Commodore – Sailing shall select one of the faster sailboats to conduct the starting sequence.. There shall be a Race Committee Boat to conduct the starting sequence for all races in which “time-on-time” handicap system is used. Races shall be started with a 5-minute sequence as set forth in Rule 26 of The Racing Rules of Sailing 2009 – 2012, including US Sailing Prescriptions. At the Skippers’ Meeting, the Rear Commodore – Sailing shall provide the countdown details and define the starting line. The sound signals shall be a horn. Flag signals shall govern over horn signals for timing the starting sequence for each race.  
  
ONE-DESIGN CLASSES – At the discretion of the Rear Commodore – Sailing, one-design classes may be started separately.
14. FINISH - The finish line shall be between a staff displaying an orange flag on the Race Committee boat and the finish mark at the opposite end of the finish line, or between the finish mark and an orange sphere as advised at the Skippers Meeting, if no Race Committee boat shall be used. All boats shall pass through the finish line from the direction of the previous mark of the course.
15. TIME LIMIT - The racing time limit shall be one hundred twenty (120) minutes for the first sailboat to finish the course. Sailboats not finishing within 30 minutes after the time limit shall be scored DNF. Races shall be abandoned if no starter has successfully rounded the first mark of the course within thirty (30) minutes of the highest rated boat’s official starting time. Distance races shall have no time limit, but may be abandoned at the discretion of the Rear Commodore – Sailing in the event of foul weather or insufficient wind.
16. SAFETY - Each boat shall carry a Coast Guard approved life jacket for each individual aboard. If possible, a boat that retires from a race should notify the Sailing Commodore before leaving the course except when unable, due to breakdown. The use of VHF Radios is encouraged, and the channel used for each race shall be decided at each event’s skipper’s meeting.
17. SOCIAL – Plan on spending time with your fellow sailors after each event under the tree near pier G for conversation and snacks.
18. REAR COMMODORE – SAILING - If you have any questions, contact the CRBA Rear Commodore - Sailing at E-mail: [sailingcommodore@crba-livingston.com](mailto:sailingcommodore@crba-livingston.com).